

# Understanding the Importance of Gateways in BPMN 2.0

David Jones



t. +44 (0) 870 991 1851  
f. +44 (0) 870 011 6412  
e. [enquiries@orbussoftware.com](mailto:enquiries@orbussoftware.com)

- ① **About the Presenter**
- ② **Introduction**
- ③ **The role of Gateways in BPMN**
- ④ **Types of Gateways in BPMN 2.0**
- ⑤ **Demonstrating the role of Gateways**
- ⑥ **Best Practice Recommendations**
- ⑦ **Conclusion and Questions**

## David Jones

Senior Consultant Architect  
Enterprise Architects

- ❑ Based in Melbourne, Australia
- ❑ Currently working as an Enterprise Architect with particular specialist knowledge in Business Architecture and Business Process Management
- ❑ Nearly 30 years experience in various disciplines, such as:
  - IT Architecture domains;
  - IT Planning;
  - Business Process Modelling
  - Process Improvements;
  - Business Architecture domains, including Business Strategy.



- ❑ One of the common points of confusion for people learning any version of BPMN is that Gateways.
- ❑ This is because Gateways essentially look like the Decision Diamonds used in traditional process mapping approaches previously to document processes.
- ❑ In this Webinar, we will discuss the importance and role of Gateways in modelling your processes using BPMN 2.0 by explaining:
  - The role of Gateways in BPMN in terms of what they are, why we need them as well as what they are used for;
  - The different types of Gateways available in BPMN 2.0 and how they are commonly used; and
  - Some best practice recommendations in how to name and use Gateways in your business process modelling.

## What are Gateways in BPMN?

- ❑ The OMG's BPMN 2.0 Specification defines a Gateway as:

*Gateways are used to control how the Process flows through Sequence Flows as they converge and diverge within a Process. If the flow does not need to be controlled, then a Gateway is not needed. The term "gateway" implies that there is a gating mechanism that either allows or disallows passage through the Gateway.*

- ❑ The modern analyst defines gateways as:

*A Gateway is a BPMN process modeling element used to control how sequence flows interact as they converge and diverge within a process. The term gateway is used to signify a mechanism by which something is either allowed or disallowed through. A gateway is represented as a diamond. Unlike activities, gateways do not represent work being done within a process flow.*

## What are Gateways used for in BPMN?

- ❑ Gateways are the way in which you control sequence flow in a process in BPMN. This can be because of the need to:
  - Route a sequence flow following a decision, using an exclusive or inclusive gateway; or alternatively
  - Undertake activities in parallel, using the parallel gateway.
- ❑ As we mentioned earlier, Gateways are a cause of confusion for many people learning BPMN.
- ❑ Why?
- ❑ Because Gateways are shaped like the Decision Diamonds used in traditional process mapping and inexperienced users believe that Gateways are equivalent to Decision Diamonds.
- ❑ Unfortunately, this is not the case.
- ❑ Decision Diamonds involves the evaluation of the decision as well as the routing based on the outcome.
- ❑ In BPMN, Gateways only route outcomes already evaluated, i.e. they do not include undertake any activity.

## Overview

- ❑ In explaining the different types of Gateways, the Object Management Group's BPMN 2.0 specification has been referenced, rather than be too influenced by personal preferences.
- ❑ As we explained in our White Paper, the Object Management Group published the BPMN 2.0 specification in 2011 and set out the representation for each gateway.
- ❑ Unlike the myriad types and sub-types of events, there are only a 6 types of Gateways:
  - Exclusive Gateways;
  - Inclusive Gateways;
  - Parallel Gateways;
  - Event Based Gateways;
  - Parallel Event Based Gateways; and
  - Complex Gateways.

## Overview (continued)

- ❑ Of these, the first three are those commonly used:
  - Exclusive Gateways;
  - Inclusive Gateways; and
  - Parallel Gateway.
- ❑ Although the Exclusive Gateways, Inclusive Gateways and Parallel Gateway are relatively straightforward to understand and use, the Event Based Gateways and Parallel Event Based Gateways are certainly very useful in the right circumstances and you should look at adding them to your process modelling repertoire as you become more comfortable is using Gateways.



## Exclusive Gateway

- ❑ The Exclusive Gateway is used to create alternative paths within a Process flow.
- ❑ It is the “diversion point in the road” for a Process.
- ❑ The Exclusive Gateway represents the need to make a decision where only one of the paths can be taken.
- ❑ An Exclusive Gateway is graphically represented in BPMN as a diamond with a single line and usually no X, as shown below:



BPMN Symbol for an Exclusive Gateway

## Inclusive Gateway

- ❑ The Inclusive Gateway is used to create both alternative and parallel paths within a Process flow.
- ❑ The Inclusive Gateway represents the need to make a decision where all conditions must be evaluated.
- ❑ Whilst the Inclusive Gateway can be used to show that all paths must be taken, it should be used in such a way that at least one of the paths is taken.
- ❑ An Inclusive Gateway is graphically represented in BPMN as a diamond with a single line and a circle inside as shown below:



BPMN Symbol for an Inclusive Gateway

## Parallel Gateway

- ❑ The Parallel Gateway is used to represent parallel paths in a process.
- ❑ The Parallel Gateway does not check any conditions and will wait for all incoming flows before triggering the parallel path.
- ❑ A Parallel Gateway is graphically represented in BPMN as a diamond with a single line and the plus symbol inside as shown below:



BPMN Symbol for a Parallel Gateway

## Event Based Gateway

- ❑ The Event-Based Gateway represents a branching point in the Process where the alternative paths that follow the Gateway are based on Events that occur rather than the evaluation of the process flow that lead to this point.
- ❑ A specific Event such as the receipt of a message from a customer, determines the path that will be taken.
- ❑ An Event Based Gateway is graphically represented in BPMN using a pentagon marker inside a double line circle, inside a diamond with a single line as shown below:



BPMN Symbol for an Event Based Gateway

## Complex Gateways

- ❑ The Complex Gateway is used to represent complex synchronisation behaviour in a process.
- ❑ A complex gateway is used when one or more of the outgoing sequence flows from the decision may be taken.
- ❑ The Complex Gateway must have a default path.
- ❑ The complex gateway is an element that would be used more in executable modelling than analytical modelling and may make more sense when used to describe a complex merge.
- ❑ The condition would determine when the next task would start.



Complex  
Gateway

BPMN Symbol for an Event Based Gateway

## Overview

- ❑ The best way to demonstrate the capabilities and importance of Gateways is to look at sample process models. We have taken the examples shown here from the BPMN 2.0 by Example document published by the Object Management Group (OMG).

# Demonstrating the role of Gateways

## Example 1

- A Pizza Order and Delivery example, which provides a good example use of Gateways:

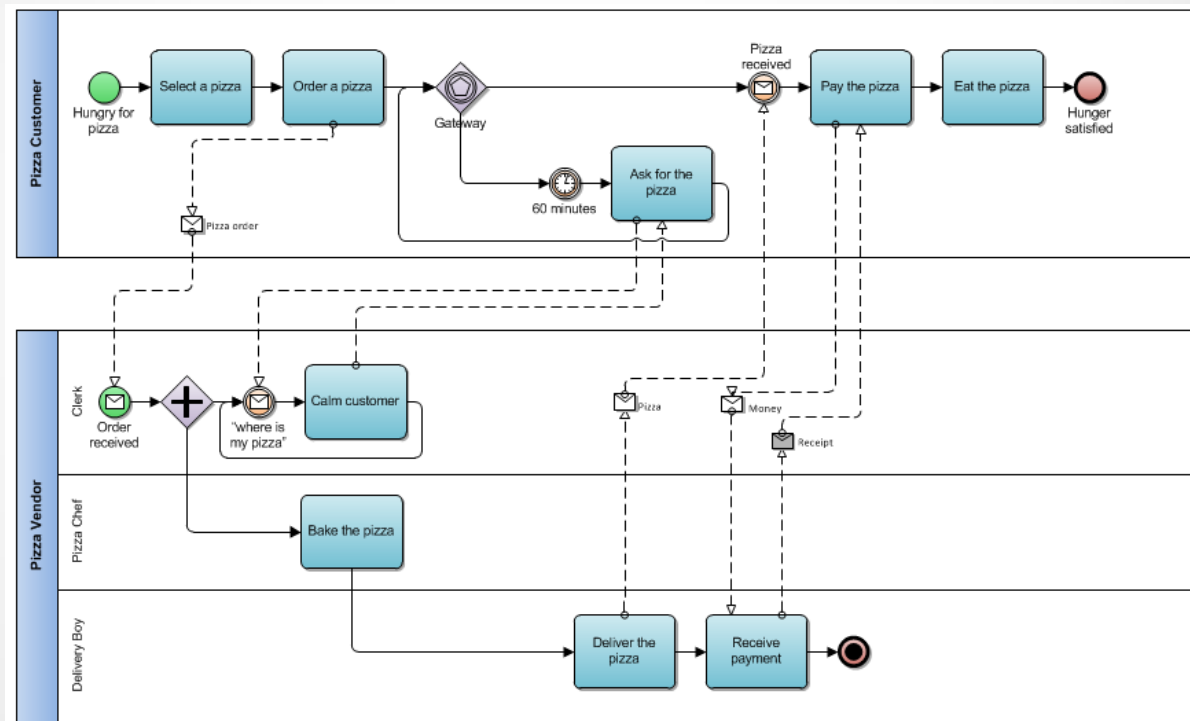

# Demonstrating the role of Gateways

## Example 2

- ❑ The following Process provides a more appropriate example that demonstrates the most common types of Gateways:

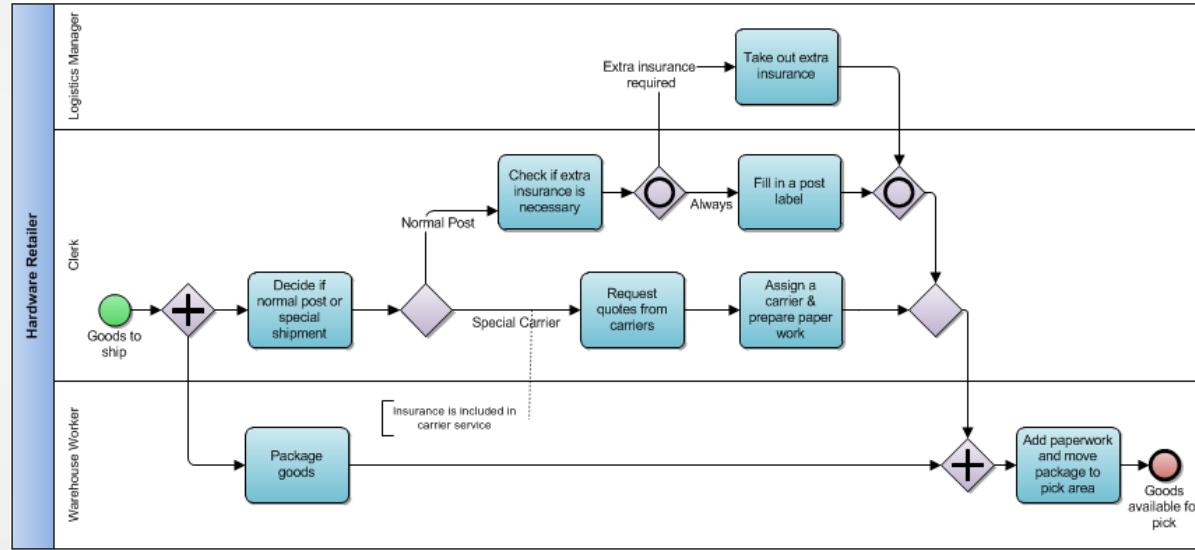



## Recommendations for Gateway naming

- ❑ Under normal circumstances, only Exclusive and Inclusive Gateways are named.
- ❑ They are best named with the Decision previously evaluated, as illustrated in the examples in the previous slides.

## Recommendations for Exclusive Gateways

- ❑ Exclusive Gateways are one of the key Gateways used in process modelling as they provide the mechanism for routing decisions (i.e. require the choice of one path from the set of available paths), consequently it is typically the most commonly used Gateway.
- ❑ They should be used whenever a single path through a Gateway is required after a condition has been evaluated in the previous Activity.

## Recommendations for Inclusive Gateways

- ❑ Although Inclusive Gateways are not as commonly used as Exclusive Gateways, they can be useful when you require one or more of the paths to be used after a condition has been evaluated in the previous Activity.

## Recommendations for Parallel Gateways

- ❑ Parallel Gateways do not provide routing based on decisions. Instead, a Parallel Gateway provides the mechanism in Process Modelling to allow multiple paths to be undertaken in Parallel.
- ❑ Consequently, their use is limited to circumstances where multiple paths are needed to be executed in parallel and to re-joining these multiple paths back together.

## Recommendations for Event Based Gateways

- ❑ Event Based Gateways provide the means of routing a Process based on waiting for the occurrence of one of two or more events.
- ❑ Although they are not commonly used, there are circumstances when Event Based Gateways are useful.
- ❑ An Event Based Gateway is to provide a means of handling waiting for the first occurrence of one of two events. A typical use of an Event Based Gateways is to provide a time-out mechanism for the handling of another event, for example using a Timer Intermediate Event to provide a time-out mechanism while waiting for the arrival of a Catching Message Event.

- ❑ Gateways are an important part of BPMN, as they are the means by which Sequence flow is controlled within a Process.
- ❑ It is important to remember that Gateways do not evaluate Decisions like the Decision Diamonds of traditional process mapping. So when you are using Exclusive and Inclusive Gateways, remember that the decisions need to be evaluated prior to the Gateway.
- ❑ We would also highly recommend that you consider how you can use the Event Based Gateways in your processes once you gain experience with BPMN 2.0.

## Do you have any questions?



Search for:  
Orbus Software Group



<https://twitter.com/OrbusSoftware>



Download this presentation and accompanying white paper from:  
(<http://orbussoftware.com/downloads/>)

Thank You.